

Prostore 500

1 Door Digital Freezer, 470lt (-15/-22 °C) - Remote, CO2

ITEM # _____

MODEL # _____

NAME # _____

SIS # _____

AIA # _____

691342 (PS04F1FRCO2)

 1-door prostore Freezer
 470lt, -22-15°C, AISI 304,
 remote, CO2 with valve

Short Form Specification

Item No. _____

Full door freezer constructed in 304 AISI stainless steel with external bottom panel in anti-corrosive material. Large digital display featuring cabinet temperature display and setting and turbo frost cycle (to rapidly cool warm loads). HACCP-compliant control with alarms and history. Frost Watch Control to defrost only when required with automatic evaporation of defrost water. Optimized airflow provides even temperature distribution on all grids. Fitted with 65 mm-thick polyurethane insulating foam. Self-closing, on-site reversible door features microswitch to switch off the fan when the door is opened and heated door frame. Hidden evaporator to guarantee higher storage capacity and less corrosion problems. Remote refrigeration unit (not included). Specific for CO2 gas, valve is included. Ventilated operation; Interior LED light. For ambient temperatures up to 43 °C. Supplied with a built-in foot pedal, 5 x 520X442mm Rilsan coated grids and n. 5 sets of 2 stainless steel grid runners. Prearranged to fit RS485 port to facilitate connection to a remote computer and integrated HACCP systems.

Main Features

- IPX5 frontal water protection.
- Large storage area suitable to contain 520x442 mm grids or shelves to improve net capacity.
- Optimized airflow within the chamber guarantees uniformity of temperature on all grids.
- Hidden evaporator thus guaranteeing higher storage capacity and less corrosion problems.
- Greater storage space: internal structure with numerous charging positions available to host grids, ensuring higher net capacity.
- Adjustable temperature range from -15°C to -22°C.
- Model requires only 1 phase 230V/50Hz supply and can be plugged straight into an existing power socket.
- Tropicalized unit.
- Complies with main international certification bodies and is CE marked.
- Prearranged for remote alarm.
- Low noise level.
- Self closing and on site reversible left/right doors.

APPROVAL: _____

Construction

- Stainless steel AISI 304 external panels (galvanized external back).
- Lockable door.
- Inner cell with rounded corners, bottom pressed in only one piece.
- Stainless steel runners and supports easily disassembled.
- Internal components removable without the use of tools to facilitate cleaning operations.
- Pressed stainless steel door handle without joints gathering dust and dirt.
- Easy access to the main components for maintenance.
- Developed and produced in ISO 9001 and ISO 14001 certified factory.
- Solenoid valve included.
- Automatic heated door frame.

User Interface & Data Management

- Large digital white-digit display with cabinet temperature display and setting and turbo frost cycle (to rapidly cool warm loads).
- Fully compliant HACCP digital control: when temperature exceeds critical limits, acoustic and visual alarms are activated. Up to two months of event are kept in memory.
- Electrolux Professional Fridge Control APP makes the life easier for our customers:
 - Monitor safety of preservation process thanks to HACCP data & alarms for precise control
 - Save time and easy data management having the possibility to send the HACCP information in excel format directly to e-mail address
 - Quick operations: set the cabinet temperature/turbocooling and set date/hour
- Large digital white-digit display with cabinet temperature display and setting. Bluetooth technology included allows to keep HACCP historical data and download them through the app.

Sustainability



- CO₂ (R744) is the refrigerant choice that's safe for the environment and delivers outstanding performance.
Eco-Friendly: Zero Ozone Depletion Potential and an ultra-low Global Warming Potential (GWP = 1).
Safe to Use: Non-toxic and non-flammable for peace of mind.
Sustainable: A natural refrigerant that supports a greener, cleaner planet.
- Frost Watch Control: fully automatic defrost starts only when ice is actually building-up in the evaporator and adapt the defrosting duration to guarantee perfect ice removal while optimizing energy efficiency consumption.
- Insulation thickness: 65 mm of polyurethane injected with ecological foaming gas cyclopentane to ensure effective insulation with minimum energy consumption (thermal conductivity: 0,020 W/m*K).
- Removable triple-chamber balloon magnetic gasket to improve insulation and reduce energy

consumption and ease of cleaning.

- Optical door microswitch to stop the fan once the door is opened, thus minimizing energy waste.
- Interior LED light to save energy and for best internal visibility.

Included Accessories

- 1 of Pedal opening for cabinets PNC 880324
- 5 of Pair of runners for 470 and 720lt prostore cabinets PNC 880335
- 5 of Rilsan-coated grid 520x442mm for Prostore 470l PNC 880342

Optional Accessories

- Stainless steel grid (520x442) PNC 880321
- Pedal opening for cabinets PNC 880324
- Kit 4 feet, height 200mm PNC 880325
- Kit of 4 feet-h=67 (marine) PNC 880326
- Kit pair of runners (marine) PNC 880327
- Base frame for 1/1 GN rack for 470lt prostore PNC 880328
- Pair of runners for 470 and 720lt prostore cabinets PNC 880335
- Rilsan-coated grid 520x442mm for Prostore 470l PNC 880342

Recommended Detergents

- S01 STAINLESS STEEL SURFACE POLISHER; 6 BOTTLES X 750ML C/T PNC 0S2881
- S05 - MULTIPURPOSE DEGREASER; 6PCS X 750ML; ADR&IMDG Limited Quantity PNC 0S3257

Front

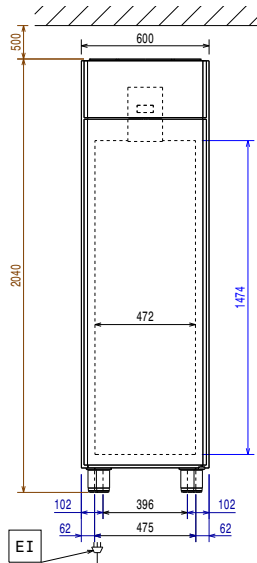

Side

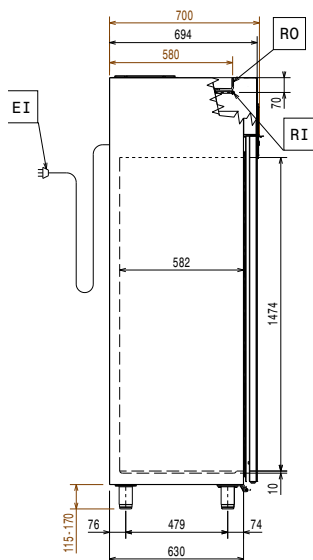

EI = Electrical inlet (power)
 RI = Refrigerant Inlet
 RO = Refrigerant Outlet

Top

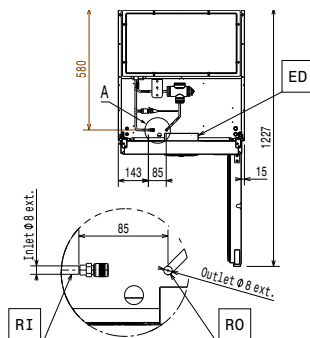

Electric

Supply voltage: 220-240 V/1 ph/50/60 Hz
 Electrical power, max: 0.16 kW

Capacity:

Number and type of grids (included): 5 - 520x442

Key Information:

Door hinges:

External dimensions, Width: 600 mm
 External dimensions, Depth: 700 mm
 External dimensions, Depth with Doors Open: 1226 mm
 External dimensions, Height: 2040 mm
 Number and type of doors: 1 Full
 Internal Dimensions, Width: 472 mm
 Internal Dimensions, Depth: 582 mm
 Internal Dimensions, Height: 1474 mm
 Height adjustment: 15/40 mm
 Type of external material: 304 AISI
 Type of internal material: 304 AISI
 Number of positions & pitch: 44; 22 mm
 Gross capacity: 470 lt

Refrigeration Data

Control type: Digital
 Condensation temperature: 55 °C
 Refrigeration type: R744
 Defrost type: Electric
 Suggested refrigeration power: 654 W
 Condition at evaporation temperature: -30 °C
 Condition at condensation temperature: 55 °C
 Condition at ambient temperature: 43 °C
 Connection pipes (remote) - outlet: 8 mm
 Connection pipes (remote) - inlet: 8 mm

Ref. Power calculated at a linear distance of 15 mt (piping)

*Note:

ISO Certificates

ISO Standards: ISO 9001; ISO 14001; ISO 45001; ISO 50001